

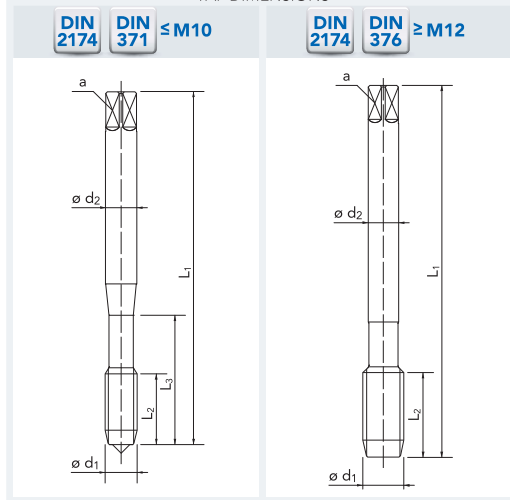

COLD FORMING TAPS - Oil grooves  
For blind and through holes  
ISO Metric coarse thread - DIN 13

TAP DIMENSIONS



APPLICATION RANGE - CUTTING SPEED m/min

ISO	MG	A80 N VAP	A80 N TiN	A80 N TiCN
P	P.1-2	• 20-25	• 40-45	• 40-45
	P.3	• 15-20	• 35-40	• 35-40
N	N.1	• 20-25	• 40-45	• 40-45
	N.2		• 40-45	• 40-45
	N.3		• 35-40	• 35-40
	N.5	• 20-25	• 40-45	• 40-45
	N.6		• 40-45	• 40-45

Ød <sub>1</sub>	P	L <sub>1</sub> js 16	L <sub>2</sub>	L <sub>3</sub>	Ød <sub>2</sub> h9	a h12	z	z	z
[mm]	[mm]	[mm]	[mm]	[mm]	[mm]	[mm]	[-]	[-]	[mm]
M 2	0,4	45	7	11	2,8	2,1	3	1,85	•
2,5	0,45	50	9	15	2,8	2,1	3	2,3	•
3	0,5	56	10	18	3,5	2,7	4	2,8	•
3,5	0,6	56	11	20	4	3	4	3,25	•
4	0,7	63	12	21	4,5	3,4	5	3,7	•
5	0,8	70	14	24,5	6	4,9	5	4,65	•
6	1	80	16	29	6	4,9	5	5,55	•
8	1,25	90	18	33	8	6,2	5	7,4	•
10	1,5	100	20	36	10	8	5	9,3	•
12	1,75	110	24	-	9	7	5	11,2	•
14	2	110	25	-	11	9	6	13,1	•
16	2	110	28	-	12	9	6	15,1	•
18	2,5	125	28	-	14	11	8	16,9	•
20	2,5	140	30	-	16	12	8	18,9	•

• = standard execution

TOOL CODE

	A80 N VAP	A80 N TiN	A80 N TiCN
			 Voorraad artikel
Tolerance	6HX	6HX	6HX
Chamfer form	C (2-3)	C (2-3)	C (2-3)
Hole type	2,5xD	2,5xD	2,5xD
Direction of cut	RH	RH	RH
Through coolant			

